



A CSW Industrials Company

# PRODUCT DATA SHEET

## DUST FREE® CARBON

Carbon/UV-C Light Whole Home Air Purification

### Description

The Dust Free® Carbon is an ozone-free, compact, duct mounted, air purification process that effectively reduces VOC's and Formaldehyde that can exist in your home's indoor air.<sup>1</sup> Dust Free's carbon technology is one of the industry's leading duct-mounted air purification processes that effectively reduces VOC's and Formaldehyde that can exist in indoor air.

### Applications

The Dust Free Carbon Air Purifier utilizes Dust Free's patent pending Carbon and Germicidal UV-C light technology to reduce VOC's and dose HVAC surfaces with germicidal UV-C light where the light shines. Professionally installed into the supply plenum of your HVAC system, the Dust Free Carbon Air Purifier uses a unique and proprietary blend of adsorbing compounds and Germicidal UV-C light.

Recommended for HVAC systems for whole home air purification, reducing VOC's, dosing mold and mildew on HVAC cooling coils.

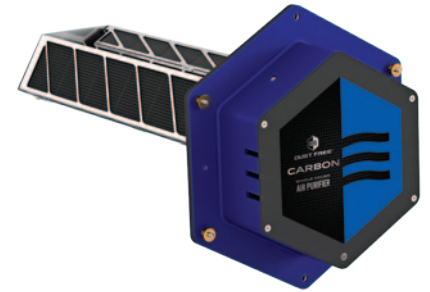

### Packaging

Code	Description	Qty per Case	Lbs per Case	Cubic Feet per Case
89224	Carbon Air Purifier, 14"	6	30	4.45

### Installation Instructions

#### Before Installation

- Read all instructions carefully. Failure to do so could damage the equipment or cause harm to yourself or others.
- Acknowledge all warnings.
- Only qualified technicians should perform the installation.

**⚠ WARNING Electric Shock Hazard. Can cause injury or death.** Electrical wiring of the unit to the HVAC system should be done by a licensed HVAC technician or electrical installer.

**⚠ WARNING UV Light Hazard. Can cause serious eye and skin damage.** Do not look at UV-C light. Wear UV-C eye and skin protection.

**⚠ WARNING Mercury Hazard. Do Not Break.** UV-C lamp contains a small amount of Mercury. May cause redness or irritation. Manage in accordance with disposal laws - [www.lamprecycle.org](http://www.lamprecycle.org)

#### Included

- Carbon Air Purifier System
- 24VAC power supply
- Core
- UV-C lamp
- 40VA transformer
- Mounting plate
- Mounting hardware
- Installation instructions

### Characteristics | Features

- Proprietary Carbon/UV-C Light multistage technology
- Reduces Formaldehyde
- Ozone-free
- Auxiliary power port to power an additional 24V Germicidal UV-C light allowing to easily add an additional UV light to any HVAC system
- Highest quality construction
- Compact

EPA Establishment No. 73316-TX-1

Visit [dustfree.com/testing](http://dustfree.com/testing) for a list of micro organisms inactivated by Dust Free products.

The product and technologies described are not medical devices, and are not intended to diagnose, treat, cure, or prevent any disease or illness.

<sup>1</sup>MS2 virus and Staphylococcus epidermis bacteria.



# DUST FREE® CARBON

## Carbon/UV-C Light Whole Home Air Purification

### Specifications

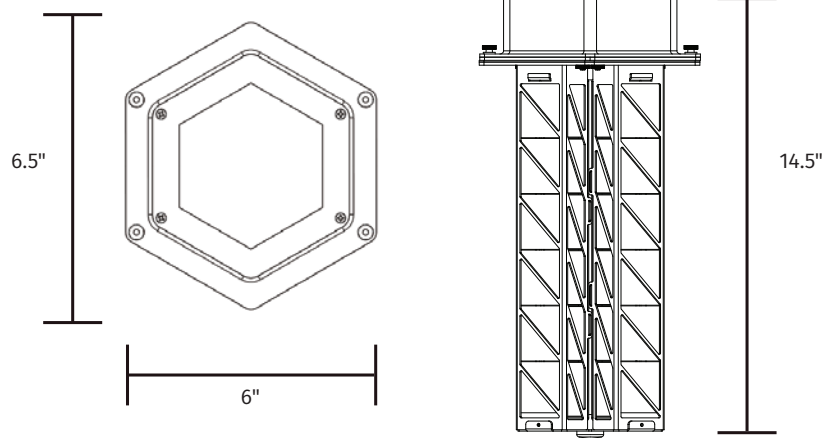

Model	Dust Free Carbon 14"
Product Code	89224
Dimensions - Power Module	6.5"H X 6"W X 14.5"L
Dimensions - Mounting Plate	8"H x 8"W
Electrical	24V 50/60Hz. Expanded range ballast 20V–32V. 1.4A. 3000V surge protection.
Weight	3 lbs
Tonnage	5 ton systems
Core life/Lamp life	4 years / 2 years (18,000 hours)
Humidity	Water resistant lamp
Replacement Core Product Code	89225
Replacement Lamp Product Code	89226

### UV Installation Notes

- This device is meant only to be installed in the duct portion of the HVAC system.
- The unit should be mounted directly to a metal surface.
- The duct work around the installation area should be clean and dry to insure proper adhesion of the gasket materials and any tape used.
- An approximate 5" opening will need to be cut into the existing duct work to install the device properly.

### Airflow Orientation

- The device can be oriented in any direction to airflow. It is recommended to orient the UV lamp to shine toward the desired area of maximum UV sterilization.

### 24VAC Electrical Requirements

- Connect black and white wires to a dedicated 40VA transformer.

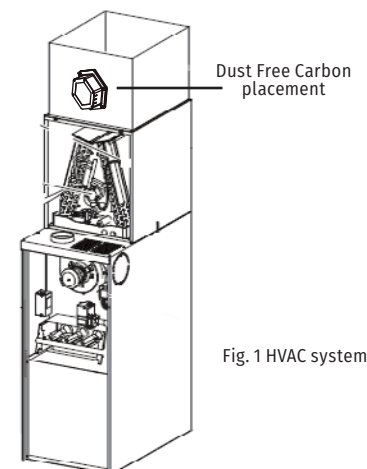

Fig. 1 HVAC system

# DUST FREE® CARBON

## Carbon/UV-C Light Whole Home Air Purification

### Metal Ductwork Installation

- Locate a suitable area of the duct for installation. Minimum 8" area.
- If needed, cut away insulation to expose metal duct.
- Mark location for 5" opening using the included mounting plate as a template.
- Cut opening for the device.
- Remove the backing from the mounting plate gasket, center mounting plate over opening, and press onto the duct. The adhesive gasket will hold the mounting plate in place.
- Secure the mounting plate using self-tapping screws.
- Insert device into opening and secure with knurled nuts.
- Connect to proper power and test operation. The operation indicator light on the face of the device should be on.

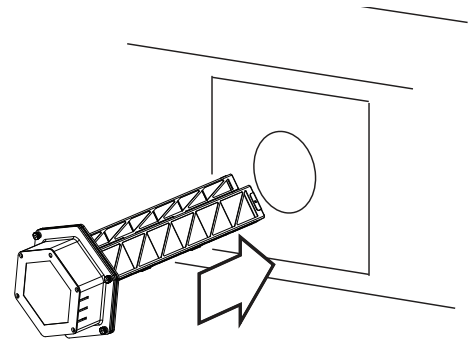

Fig. 2 Cut opening in duct, attach mounting plate, and install device

### Fiberglass Ductwork Note

- For fiberglass ductwork installations use 3" toggle bolts to attach mounting plate.

### Maintenance/UV Lamp Indicator

- For optimal performance, replace the device core each year and the UV-C lamp every 2 years, even if the UV-C lamp appears to be operating normally..
- The operation indicator on the face of the device should glow during normal operation. If the indicator does not glow and the unit has power, the device core should be replaced.

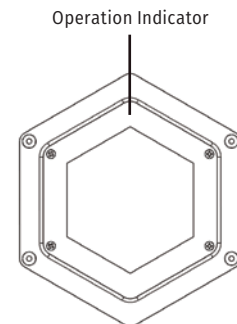

Fig. 3 Operation indicator

### Changing the Core or UV-C Lamp

- Disconnect the device from power.
- Removed the knurled nuts securing the device and remove the device from the core.
- Remove the screws securing the core.
- Remove the core from the device and dispose of properly. **Note: If only changing the UV-C lamp, detach lamp from device and dispose of properly.**
- Secure the new core or new UV-C lamp to the device.
- Reverse the previous steps to return the device to operation.

### Disposal of Core or UV-C Lamp

Dispose of spent core and UV-C lamp at your local recycling center.

### Limited Warranty

7-yr limited; 2-yr on core

For more information on our product limited warranty, visit [RectorSeal.com](http://RectorSeal.com)

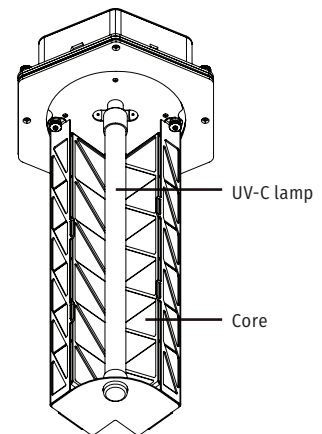

Fig. 4 Replace core each year.  
Replace UV-C lamp every 2 years.